

Large Coil Noise Canceling System (LCNCS) User's manual and installation instructions

This product is mainly designed for permanent installation on a guitar, having one or more single coil magnetic pickups. The LCNCS is usually fit inside of the guitar body in a small channel routed under a pickguard or the top layer of wood capped guitars at the time the guitar was first build. The LCNCS effectively eliminates the noise while the single coil pickup tone retains unaltered.

It is strongly recommended the LCNCS installation to be done by professional service of a guitar builder or guitar repair shop. Drilling holes, scratching insulation or heavy bending of the LCNCS could badly damage the unit and cause you to lose all terms of the warranty.

LCNCS Models

Model Number	Noise level	Best matched Single coil pickup type
LCNCS STD	10	Alnico rod poles pickups, 6-8 KOhm resistance
LCNCS POW	15	Alnico rod poles 8-12 KOhm or Steel poles 6-10KOhm
LCNCS HOT	20	Steel screw poles P90 pickups, 7-9 KOhm resistance

Basic requirements:

1. All single coil pickups need to be same kind (i. e. Alnico rod poles, steel screw poles etc.)
2. All pickups need to be wound in the same direction and have same magnetic polarity (if there is a RWRP pickup this pickup needs to be reversed or replaced with a regular one)
3. The pickups switching does not include any "in series" or "out of phase" combination.
4. The pickup selector switch, the volume and tone pots, all pickups and the output jack operate normally.

Preparing guitar with pickguard for LCNCS installation:

1. Pull OFF all strings from the tuners to get a full access to the pickups and pickguard.
2. On the guitar front - unscrew and remove the entire pickguard.
3. Take a picture or do a simple sketch to memorize the original wiring of the guitar electronics and the pickup wires connections for any future references.
4. If the pickup wires are braided type you will need to insulate them using shrink tubing or plastic jacket tubing so the pickup wires are not connected to each other or to the switch wire via the braided shield.
5. Carefully inspect the pickguard location and its overall shape and locate the large coil (LC) channel route geometry. The LC path should not be visible after you place back the pickguard, and the LC trace should not cross any pickup, potentiometer, switch and/or wires.
6. Route the LC channel about 3 mm wide and about 10-12 mm deep then make sure it fits the LC.
7. Find the right place for the Adjusting PCB inside the control cavity.

LCNCS installation steps:

- A. Cut or unsolder the three pickup ground wires (Ng Mg and Bg) soldered to the volume potentiometer housing.
- B. Tin with soldering gun and fresh solder wire one of the short ground wires (G1) left on the Volume potentiometer.
- C. Solder the wires coming out of the Adjusting PCB as follows:
=Green wire to G1; White wire to Ng; Orange wire to Mg; Blue wire to Bg. Then insulate the created soldering joints.
=Connect yellow wire from the adjusting PCB to yellow wire from the LCNCS; red wire from the adjusting PCB to red wire from the LCNCS and insulate the created wire joints.
- D. Carefully shape and position the LCNCS within the routed LC channel and secure it using some tape pieces and/or paper shims. After finishing all soldering and insulations, shape the wire harness and place back the pickguard with the pickups at its original location and screw it in using just a few mounting screws. Keep the adjusting PCB outside of the pickguard until you finish the noise canceling adjustments.

Adjusting the LCNCS for best noise cancellation:

1. Put ON some of the guitar strings (at least one), and turn the guitar volume and tone controls to their "MAX".
2. Connect the guitar to a guitar amplifier using a guitar cable.
3. Use a correct size screwdriver to adjust the blue trim pots located on the adjusting PCB.
4. Turn the two trim pots on the adjusting PCB to their "MAX" (100%). In this way you will be able to hear some basic hum noise.
5. Turn "ON" the guitar amplifier and set it up with a gain and loudness, so you can hear some noticeable hum noise. Play over the strings to check that all pickups operate normally and the hum noise has almost the same level at all 5 position of the pickup selector switch SW1.
6. Hold the guitar as you would play on it and get a position near the amplifier but not less than 3 feet (1 meter). Best noise canceling result will be achieved with the amplifier located behind your back and the guitar approximately parallel to the amplifier's front face.
7. Put the pickup selector switch SW1 at position "1" (Bridge pickup only). Turn down (CCW) VR1 trim pot to reduce the noise level. If the noise increases instead of decreasing, unplug the guitar from the amplifier remove the pickguard again and swap the wires connection as follows: yellow wire from the adjusting PCB to the red wire from the LCNCS; red wire from the adjusting PCB to the yellow wire from the LCNCS. Now turn down VR1 trim pot until get an optimum noise cancellation at position "1".
8. Put the pickup selector switch at position "5" (Neck pickup only). Turn slowly down (CCW) VR2 trim pot to reduce the noise until get an optimal noise cancellation at position "5".

9. You can now go back and forth through all 5 positions (Bridge; B+M; M; M+N; Neck) of the SW1 and fine adjust the locations of the VR1 and VR2 until you get the best noise cancellation. After you are satisfied with the noise reduction result, wrap out the adjusting PCB with a small plastic bag or piece of foam, and insert it under the pickguard.
10. Align the guitar pickguard and screw it in using all mounting screws. Double check for normal operation of the guitar.

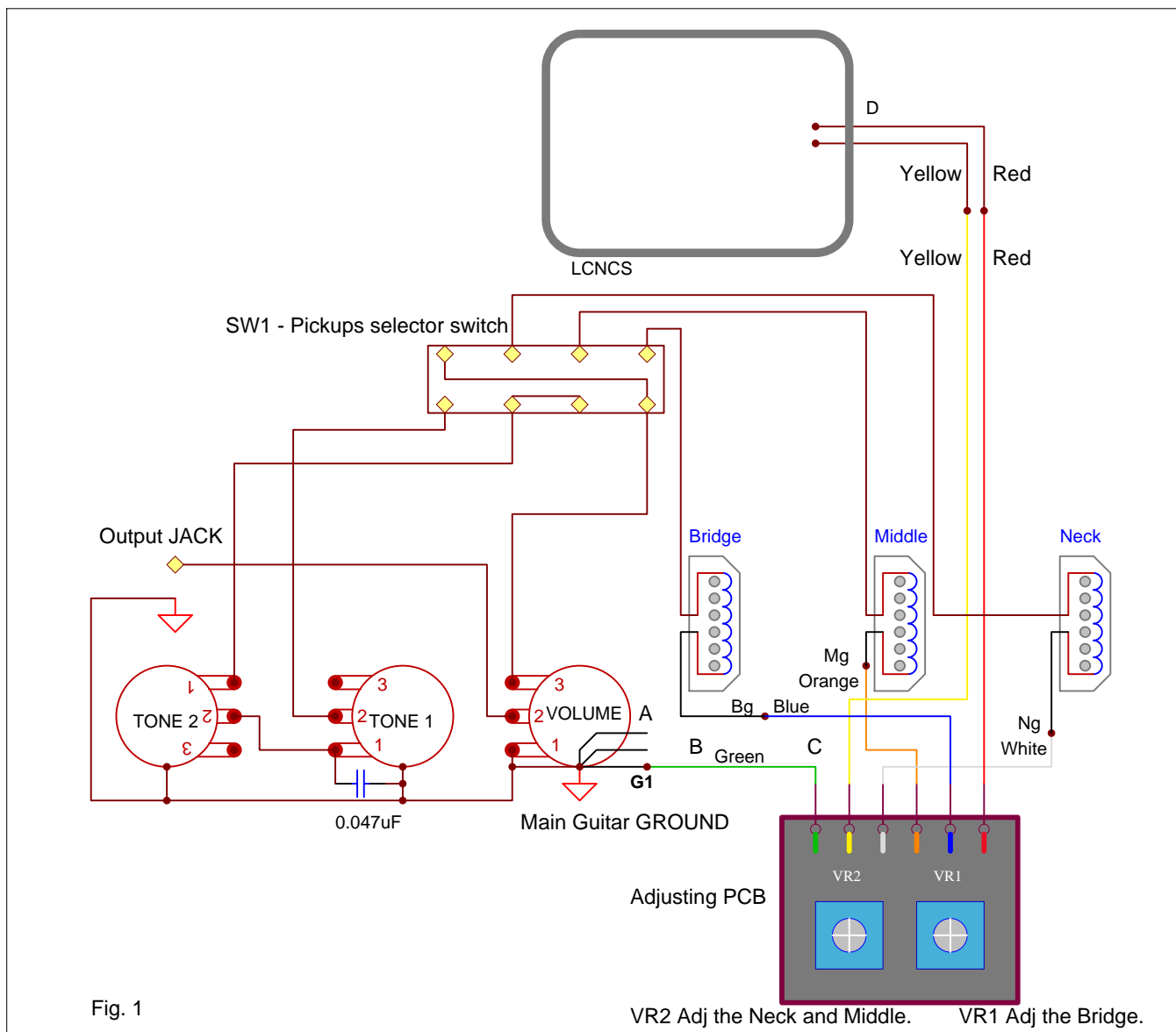

Terms and Limited Warranty

RETURNS & EXCHANGES:

We offer to the original purchaser the following terms of Limited Warranty:

1. Four weeks money back policy (excluding shipping and handling) for customers not satisfied with the purchase.
2. One year of warranty for all moving parts (i.e. trim potentiometers) of the product.
3. Two years warranty for all non-moving parts (i. e. - capacitors, resistors etc.) of the product.

Ilitch Electronics reserves the right, based on visual observing and electrical measuring, to determine what has caused a defect. Damages caused by accident, abuse, alteration, or misuse are not covered by this warranty. Product appearance and normal "wear and tear" (worn paint, scratches, etc.) are not covered by this warranty.

Customer's Name:..... Date of purchase :.....

All rights reserved without notification.
 ILITCH ELECTRONICS LLC
 Camarillo, CA, 93010
 Phone: 805 284 2775;
 email: ilitch@ilitchelectronics.com
 Web: www.ilitchelectronics.com