

Back plate noise canceling system (BPNCs) User's manual and installation instructions

This product is mainly designed for retrofit on a guitar, having one or more single coil magnetic pickups. The BPNCs is either replacing an existing back plate tremolo cover or it is adapted to fit on a guitar originally not having a tremolo back plate. The BPNCs is usually placed on the back of the guitar body.

The BPNCs contains an extremely low impedance coil assembly so it effectively eliminates the noise by 80 - 90% while the single coil pickup tone retains unaltered. The BPNCs is an easy to install passive system.

The best way to install the BPNCs is to use professional service of a guitar builder or guitar repair shop but it can be also installed by anyone that is familiar with guitar electronics, guitar assembling and wire soldering.

Drilling holes, or bending the BPNCs could badly damage the unit and cause you to lose all terms of the warranty.

BPNCs Models

Model	Noise level	Best matching single coil pickup type
BPNCs STD	10	Alnico rod poles pickups, 5-8 KOhm resistance
BPNCs POW	15	Alnico rod poles 8-12 KOhm or Steel poles 6-10KOhm
BPNCs HOT	20	Steel screw poles P90 pickups, 7-9 KOhm resistance

Basic requirements:

1. All single coil pickups need to be same kind (i. e. Alnico rod poles),
2. All pickups need to be wound in the same direction and the same magnetic polarity (if there is a RWRP pickup this pickup needs to be replaced with a regular one)
3. The pickups switching does not include any "in series" or "out of phase" combination.
4. The pickup selector switch, the volume and tone pots, all pickups and the output jack operate normally.

Preparing the guitar for BPNCs Installation:

1. Pull OFF all strings from the tuners. Now you can easily access the entire pickguard assembly.
2. On the guitar back - unscrew and remove the original plastic back plate.
3. On the guitar front - unscrew all mounting screws that hold the pickguard to the guitar body.
4. Carefully flip the pickguard assembly around its bottom side so you can see all electronic parts at a glance. Take the Adjusting PCB and make sure that you are able to fit both the red and the yellow cables through the hole that connects the Electronic control cavity and the Tremolo cavity on the guitar back. If the hole is not big enough to fit the two cables you need to either enlarge the original hole, or drill an additional small hole next to the original one.

BPNCs installation steps:

- A. Cut the three pickup ground wires (usually black) soldered to the housing of the Volume potentiometer at 1/2" from the soldering spot.
- B. Strip one of the short ground wires on the Volume pot (G1) and all three pickup ground wires (Bg, Mg, Ng) by 1/8" and tin them with soldering gun and fresh solder wire.
- C. Solder the cables coming out of the Adjusting PCB as follows:
=Green wire to G1; White wire to Ng; Orange wire to Mg; Blue wire to Bg. Then isolate the created soldering joints.
=Run the red and yellow wires together through a hole connecting the guitar electronics cavity with the tremolo cavity.
=Check for about 2 inches (5 centimeters) availability of the red and yellow wires in the tremolo cavity.
- D. Flip the pickguard assembly back to its original position and screw some of the top located screws to hold it. Do not mount the bottom located screws so the Adjusting PCB could be easily placed inside later.
- E. Turn over the guitar with the tremolo cavity faced up. Solder the wires coming out of the adjusting PCB with the cables coming out from the BPNCs as follows: yellow wire from the adjusting PCB to yellow wire from the BPNCs; red wire from the adjusting PCB to red wire from the BPNCs. Then isolate the created soldering joints.
- F. Position the BPNCs with the chamfered edge facing out, place and screw in some of the back plate mounting screws.

Adjusting the BPNCs for best noise cancellation:

1. Put back ON some of the guitar strings (at least one), then turn the guitar volume and tone controls to their "MAX".
2. Use a guitar cable to connect the guitar to a guitar amplifier.
3. Use a correct size screwdriver to adjust the blue trim pots located on the adjusting PCB.
4. Turn the two trim pots located on the adjusting PCB to their "MAX" (100%). In this way the guitar is at its original mode as the BPNCs system hasn't been installed.
5. Turn "ON" the guitar amplifier and set it up with a gain and loudness, so you can hear some noticeable hum noise. Play over the strings to check that all pickups operate normally and the hum noise has almost the same level at all 5 position of the pickup selector switch SW1. **Now set the two trim pots VR1 and VR2 to their middle position (50%)**
6. Hold the guitar as you would play it and get a position near the amplifier but not less than 3 feet (1 meter). Best noise canceling result will be achieved with the amplifier located behind your back and the guitar approximately parallel to the amplifier front face.
7. Put the pickup selector switch at position "1" (only Bridge pickup). Turn down (CCW) VR1 trim pot to reduce the noise level. If the noise increases instead of decreasing, unplug the guitar from the amplifier, unscrew the BPNCs (go to step E of the installation instructions) and swap the wires connection: yellow wire from the adjusting PCB to the red wire from the BPNCs; and red wire from the adjusting PCB to the yellow wire from the BPNCs. Screw back the BPNCs and turn down VR1 trim pot until you get optimum noise cancellation at position "1".
8. Put the pickup selector switch at position "4" (Middle and Neck pickups in parallel). Turn slowly down VR2 trim pot to reduce the noise until you get optimal noise cancellation at position "4".

9. You can now go back and forth through all 5 positions of the SW1 and fine adjust the locations of the VR1 and VR2 until you get optimum noise cancellation. After you are satisfied with the noise reducing result wrap out the adjusting PCB with a small plastic bag or piece of foam, and insert it into the guitar electronics cavity.
10. Align the pickguard and screw in the rest of the pickguard mounting screws. Check for normal operation of the guitar.

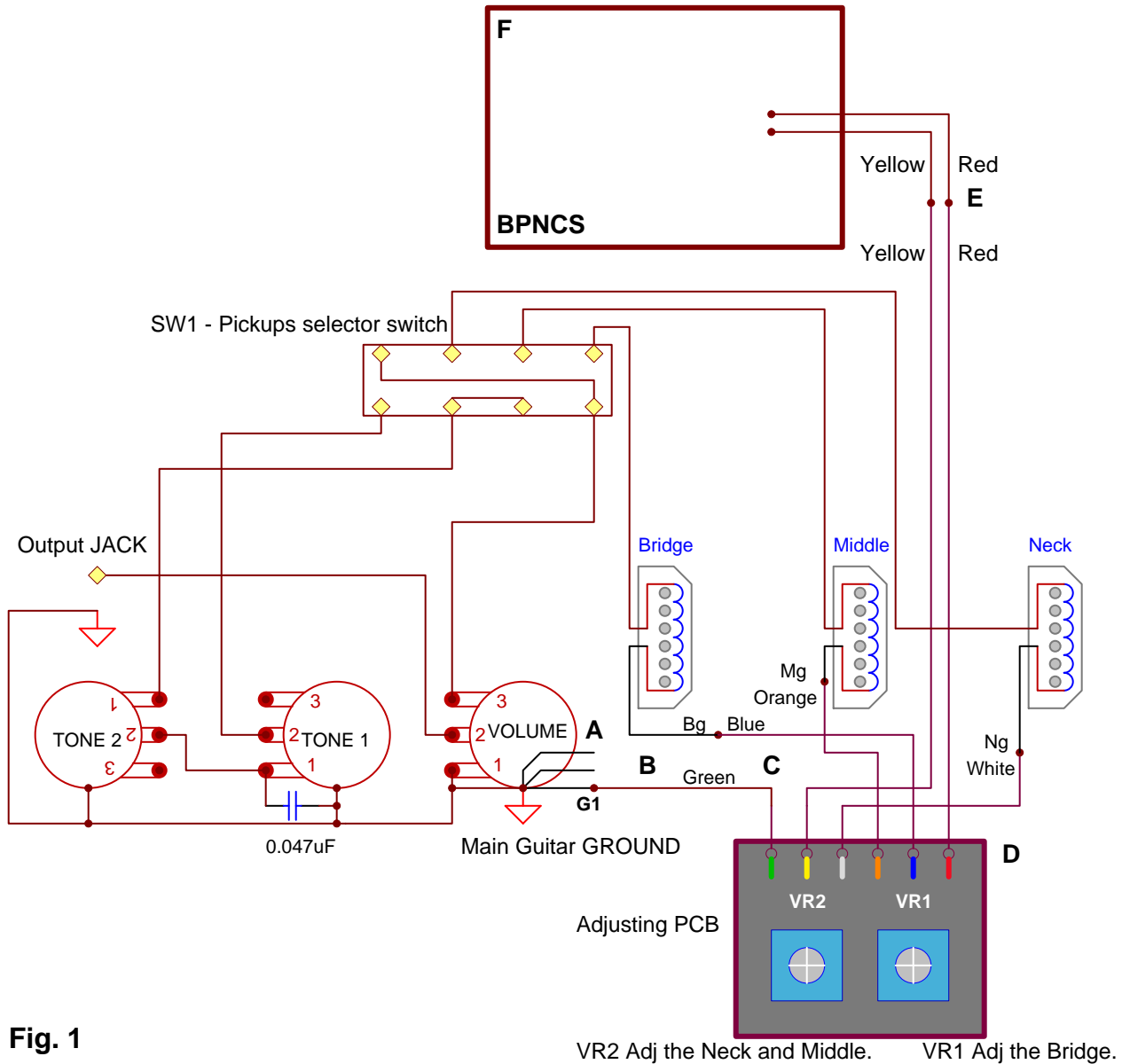

Fig. 1

VR2 Adj the Neck and Middle. VR1 Adj the Bridge.

Terms and Limited Warranty

RETURNS & EXCHANGES:

We offer to the original purchaser the following terms of Limited Warranty:

1. Four weeks money back policy (excluding shipping and handling) for customers not satisfied with the purchase.
2. One year of warranty for all moving parts (i.e. trim potentiometers) of the product.
3. Two years warranty for all non-moving parts (i.e. - capacitors, resistors etc.) of the product.

Ilitch Electronics reserves the right, based on visual observing and electrical measuring, to determine what has caused a defect. Damages caused by accident, abuse, alteration, or misuse are not covered by this warranty. Product appearance and normal "wear and tear" (worn paint, scratches, etc.) are not covered by this warranty.

Customer's Name:..... Date of purchase :.....

All rights reserved without notification.
 ILITCH ELECTRONICS LLC
 Camarillo, CA, 93010
 Phone: 805 284 2775;
 www.ilitchelectronics.com