

PGNCS-JBV (Pick Guard Noise Canceling System Jazz Bass 5 strings)

User's manual and installation instructions

This product is mainly designed for retrofit on a 5 strings Jazz Bass guitar, having two single coil magnetic pickups. The PGNCS-JBV is replacing the existing pickguard originally mounted on the front of the guitar body.

The PGNCS-JBV effectively eliminates the noise while the single coil pickup tone remains unaltered. The PGNCS-JBV is an easy to install passive system.

The best way to install the PGNCS-JBV is to use professional service of a guitar builder or guitar repair shop but it can be also installed by anyone that is familiar with guitar electronics, guitar assembling and wire soldering.

Drilling holes, scratching insulation or heavy bending of the PGNCS-JBV could badly damage the unit and cause you to lose all terms of the warranty.

Basic requirements:

1. All single coil pickups need to be the same kind (i. e. Alnico rod poles)
2. All pickups need to be wound in the same direction and have same magnetic polarity (if there is a RWRP pickup this pickup needs to be reversed or replaced with a regular one)
3. The pickups switching does not include any "in series" or "out of phase" combination.
4. All components (pickups, switches, volume and tone pots, and output jack) operate normally.

Tools and materials needed for installation:

Soldering gun, screw driver, wire cutters, soldering wire, shrink tubing. Optional: digital multimeter, piece of foam, small plastic bag, electrical/masking tape.

Preparing the guitar for PGNCS-JBV Installation:

1. Pull OFF all strings from the tuners. Now you can easily access the entire pickguard assembly.
2. Remove the existing pickguard and save it if needed.
3. Unscrew the front control cavity screws and open the control cavity assembly.
4. Take pictures or do a simple sketch to memorize the original wiring of your guitar electronics and the pickup wires connections for any future references.
5. Take the new PGNCS-JBV pickguard and run the red and yellow wires through same tunnel where the neck pickup wires run to the control cavity.
6. If you need to modify the single coil pickups - modify them according to the instructions and schematic attached.
7. Take the Adjusting PCB and make sure you are able to fit it inside of the control cavity easily.

PGNCS-JBV installation steps:

- A. Cut or unsolder the pickup ground wires (Ng and Bg) that were soldered to the Volume potentiometer housing.
- B. Tin with soldering gun and fresh solder wire one of the short ground wires (G1) left on the Volume potentiometer.
- C. Solder the cables coming out of the Adjusting PCB as follows:
=Green wire to G1 (Ground); White wire to Ng; Blue wire to Bg. Later insulate the created soldering joints.
=Connect the red and yellow wires from the PGNCS-JBV coil to the red and yellow wires from the adjusting PCB and insulate the created joints.
- D. Carefully position the PGNCS-JBV and align the mounting holes to match with the original ones. After finishing all soldering and insulations, shape the wire harness, place back the PGNCS-JBV and screw it in using some of the mounting screws. Keep the adjusting PCB outside of the control cavity until you finish the noise canceling adjustments.

Adjusting the PGNCS-JBV for best noise cancellation:

1. Put ON at least one guitar string, and turn the guitar volume and tone controls to their "MAX".
2. Connect the guitar to a guitar amplifier using a guitar cable.
3. Use a correct size screwdriver to adjust the blue trim pots located on the adjusting PCB.
4. Turn the two trim pots on the adjusting PCB to their "MAX" (100%). In this way you will be able to hear some basic hum noise.
5. Turn "ON" the guitar amplifier and set it up with a gain and loudness, so you can hear some noticeable hum noise. Play over the strings to check that the two pickups operate normally and the hum noise has almost the same level at all positions of the two Volume pots. Keep the Tone pot all the way up.
6. Hold the guitar as you would play it and get a position near the amplifier but not less than 3 feet (1 meter). Best noise canceling result will be achieved with the amplifier located behind your back and the guitar approximately parallel to the amplifier's front face.
7. Put the Bridge Volume to MAX and Neck Volume to MIN (Bridge pickup only). Turn down (CCW) VR1 trim pot to reduce the noise level. If the noise increases instead of decreasing, unplug the guitar from the amplifier and swap wires connection as follows: yellow wire from the adjusting PCB to the red wire from the PGNCS-JBV; red wire from the adjusting PCB to the yellow wire from the PGNCS-JBV. Now turn down VR1 trim pot until get an optimum noise cancellation for the Bridge pickup only.
8. Put the Neck Volume to MAX and Bridge Volume to MIN (Neck pickup only). Turn down (CCW) VR2 trim pot to reduce the noise level until you get an optimum noise cancellation for the Neck pickup only.
9. You can now go back and forth through all positions of the two Volume pots and fine adjust the locations of the VR1 and VR2 until you get the best noise cancellation. After you are satisfied with the noise reduction result, wrap out the adjusting PCB with a small plastic bag or piece of foam, and insert it under the control cavity cover.
10. Screw in all the rest of the mounting screws, set up the guitar, plug it in and double check for its normal operation.

Basic Wiring diagram:
 (find more wiring diagrams on the website - www.ilitchelectronics.com/wirings/)

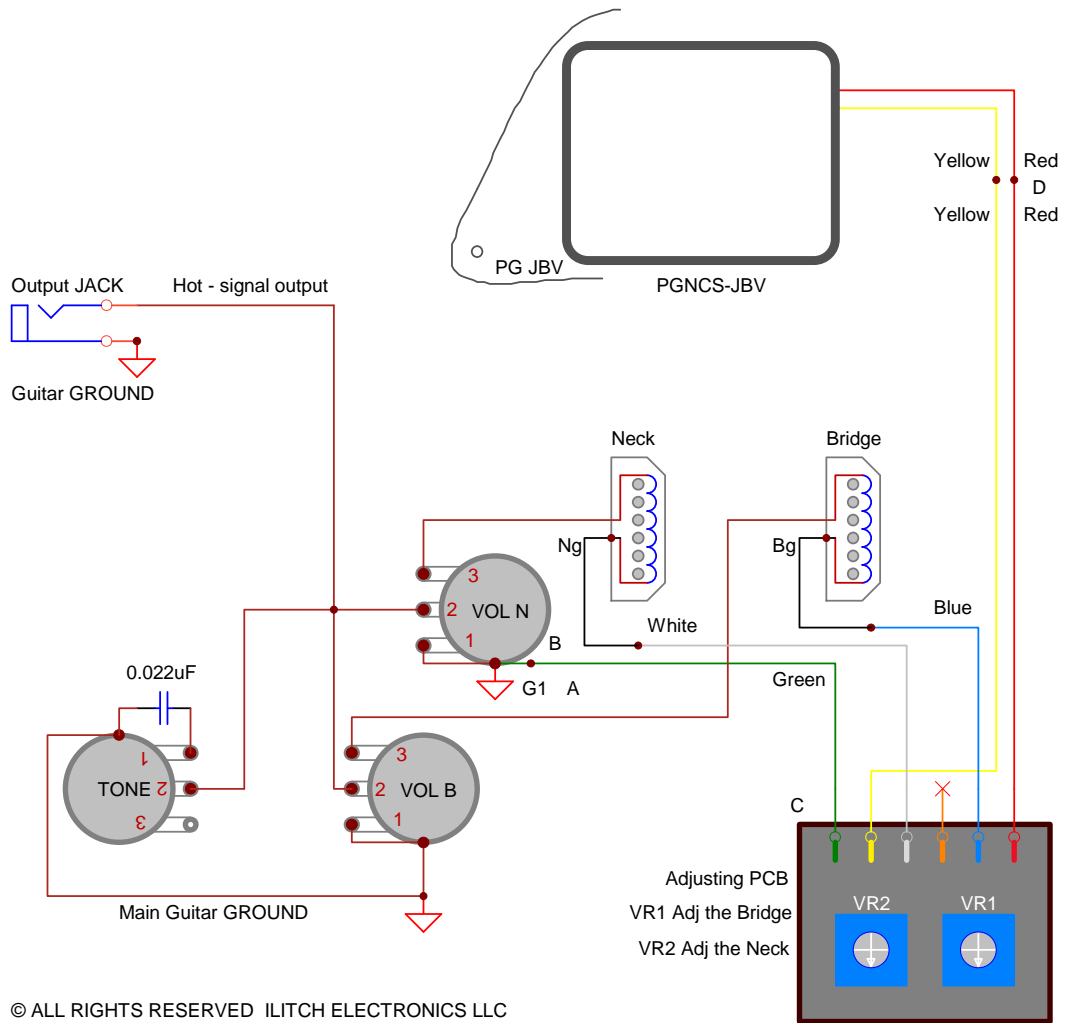

Terms of Limited Warranty. RETURN & EXCHANGE POLICY:

We offer to the original purchaser (For DIRECT SALES from ILITCH ELECTRONICS ONLY) the following terms of Limited Warranty and RETURN & EXCHANGE POLICY:

1. One year of warranty for all moving parts (i.e. trim potentiometers) of the product.
2. Two years warranty for all non-moving parts (i. e. - capacitors, resistors etc.) of the product. Ilitch Electronics reserves the right, based on visual observing and electrical measuring, to determine what has caused a defect. Damages caused by accident, abuse, alteration, or misuse are not covered by this warranty. Product appearance and normal "wear and tear" (worn paint, scratches, etc.) are not covered by this warranty.
3. We offer a four weeks money back policy for customers not satisfied with the purchase. You have to contact us first to get a return authorization number (RAN).

A refund will exclude all shipping and handling costs PayPal fees and an additional 15% restocking fee will be applied. The product needs to be in its original condition and packaging that you have received it from us.

Customer's Name:..... Date of purchase :.....

All rights reserved without notification.
 ILITCH ELECTRONICS LLC
 Camarillo, CA, 93010
 Phone: 805 284 2775;
 email: ilitch@ilitchelectronics.com
 Web: www.ilitchelectronics.com