

## Pick Guard Noise Canceling System - Tele (PGNCS-T) User's manual and installation instructions

This product is mainly designed for retrofit on a Tele style guitar, having three (3) single coil guitar pickups. The PGNCS-T is replacing the existing Tele pickguard originally mounted on the front of the guitar body.

The PGNCS-T effectively eliminates the noise while the single coil pickup tone retains unaltered. The PGNCS-T is an easy to install passive system.

The best way to install the PGNCS-T is to use professional service of a guitar builder or guitar repair shop but it can be also installed by anyone that is familiar with guitar electronics, guitar assembling and wire soldering.

Drilling holes, scratching insulation or heavy bending of the PGNCS-T could badly damage the unit and cause you to lose all terms of the warranty.

### PGNCS-T Models

Model	Noise level	Best matching single coil pickup type
PGNCS-T VNT	10	Alnico rod poles pickups, 5-7 KOhm resistance
PGNCS-T STD	12	Alnico rod poles 6-10 KOhm or Steel poles 5-8 KOhm
PGNCS-T HOT	16	Steel screw poles (NOT P90) pickups, 7-10 KOhm resistance

### Basic requirements:

1. All single coil pickups need to be same kind (i. e. Alnico rod poles, steel screw poles etc.)
2. All pickups need to be wound in the same direction and have same magnetic polarity (if there is a RWRP pickup this pickup needs to be reversed or replaced with a regular one)
3. The pickups switching does not include any "in series" or "out of phase" combination.
4. The pickup selector switch, the volume and tone pots, all pickups and the output jack operate normally.

### Preparing the guitar for PGNCS-T Installation:

1. Pull OFF all strings from the tuners. Now you can easily access the entire pickguard assembly.
2. Remove the existing pickguard and save it if needed.
3. Unscrew the front control cavity screws and open the control cavity assembly
4. Take pictures or do a simple sketch to memorize the original wiring of your guitar electronics and the pickup wires connections for any future references.
5. Take the new PGNCS-T pickguard and run the red and yellow wires through same tunnel where the neck pickup wires run to the control cavity.
6. If you need to modify the single coil pickups - modify them according to the instructions and schematic attached.
7. Take the Adjusting PCB and make sure that you will be able to fit it inside of the control cavity easily.

### PGNCS-T installation steps:

- A. Cut or unsolder the pickup ground wires (Ng, Mg and Bg) that were soldered to the Volume potentiometer housing.
- B. Tin with soldering gun and fresh solder wire one of the short ground wires (G1) left on the Volume potentiometer.
- C. Solder the cables coming out of the Adjusting PCB as follows:  
=Green wire to G1 (Ground); White wire to Ng; Orange wire to Mg; Blue wire to Bg. Then insulate the created soldering joints.  
=Connect the red and yellow wires from the PGNCS-T coil to the red and yellow wires from the adjusting PCB and insulate the created joints.
- D. Carefully position the PGNCS-T and align the mounting holes to match with the original ones. After finishing all soldering and insulations, shape the wire harness, place back the PGNCS-T and screw it in using some of the mounting screws. Keep the adjusting PCB outside of the control cavity until you finish the noise canceling adjustments.

### Adjusting the PGNCS-T for best noise cancellation:

1. Put ON some of the guitar strings (at least one), and turn the guitar volume and tone controls to their "MAX".
2. Connect the guitar to a guitar amplifier using a guitar cable.
3. Use a correct size screwdriver to adjust the blue trim pots located on the adjusting PCB.
4. Turn the two trim pots on the adjusting PCB to their "MAX" (100%). In this way you will be able to hear some basic hum noise.
5. Turn "ON" the guitar amplifier and set it up with a gain and loudness, so you can hear some noticeable hum noise. Play over the strings to check that all pickups operate normally and the hum noise has almost the same level at all position of the pickup selector switch SW1.
6. Hold the guitar as you would play on it and get a position near the amplifier but not less than 3 feet (1 meter). Best noise canceling result will be achieved with the amplifier located behind your back and the guitar approximately parallel to the amplifier's front face.
7. Put the pickup selector switch SW1 at position "1" (Bridge pickup only). Turn down (CCW) VR1 trim pot to reduce the noise level. If the noise increases instead of decreasing, unplug the guitar from the amplifier and swap wires connection as follows: yellow wire from the adjusting PCB to the red wire from the PGNCS-T; red wire from the adjusting PCB to the yellow wire from the PGNCS-T. Now turn down VR1 trim pot until get an optimum noise cancellation at position "1".
8. Put the pickup selector switch at position Neck pickup only. Turn slowly down (CCW) VR2 trim pot to reduce the noise until get an optimal noise cancellation. If you have a Middle pickup adjust VR2 for its best noise canceling.
9. You can now go back and forth through all positions of the pickup selector switch SW1 and fine adjust the locations of the VR1 and VR2 until you get the best noise cancellation. After you are satisfied with the noise reduction result, wrap out the adjusting PCB with a small plastic bag or piece of foam, and insert it under the control cavity cover.

10. Screw in all the rest of the mounting screws, set up the guitar, plug it in and double check for its normal operation.

---

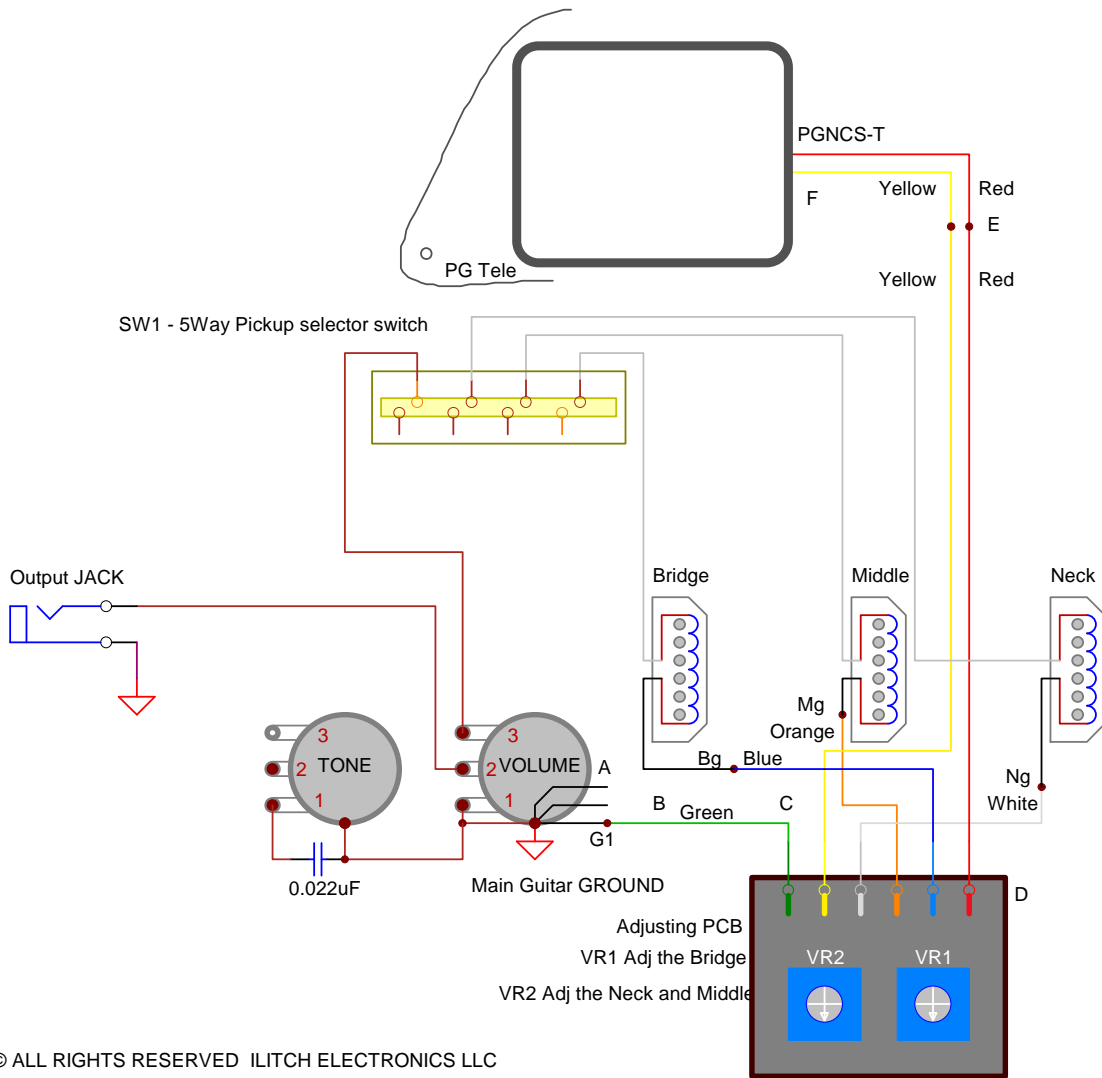

---

**Terms and Limited Warranty**

**RETURNS & EXCHANGES:**

We offer to the original purchaser the following terms of Limited Warranty:

1. Four weeks money back policy (excluding shipping and handling) for customers not satisfied with the purchase.
2. One year of warranty for all moving parts (i.e. trim potentiometers) of the product.
3. Two years warranty for all non-moving parts (i.e. - capacitors, resistors etc.) of the product.

Ilitch Electronics reserves the right, based on visual observing and electrical measuring, to determine what has caused a defect. Damages caused by accident, abuse, alteration, or misuse are not covered by this warranty. Product appearance and normal "wear and tear" (worn paint, scratches, etc.) are not covered by this warranty.

Customer's Name:..... Date of purchase :.....

All rights reserved without notification.  
 ILITCH ELECTRONICS LLC  
 Camarillo, CA, 93010  
 Phone: 805 284 2775;  
 email: ilitch@ilitchelectronics.com  
 Web: www.ilitchelectronics.com