

# Cavity Noise Canceling System - R2 (CVNCS-R2)

## User's manual and installation instructions

This product is mainly designed for retrofit on a guitar, having one or more single coil magnetic pickups. The CVNCS-R2 is designed to be attached on the back of the guitar body and connected through the control cavity.

The CVNCS-R2 contains a low impedance coil assembly so it effectively eliminates the noise while the single coil pickup tone remains unaltered. The CVNCS-R2 is an easy to install passive system.

The best way to install the CVNCS-R2 is to use professional service of a guitar builder or guitar repair shop but it can be also installed by anyone that is familiar with guitar electronics, guitar assembling and wire soldering.

Drilling holes, scratching insulation or heavy bending of the CVNCS-R2 could badly damage the unit and cause you to lose all terms of the warranty.

### **Tools and materials needed for installation:**

Soldering gun, screw driver, wire cutters, soldering wire, shrink tubing. Optional: a digital multimeter, a piece of foam, small plastic bag, electrical/masking tape.

### **Basic requirements:**

1. All single coil pickups need to be same kind (i. e. P90 with screw pole pieces) and within the selected best matching DC resistance range
2. All pickups need to be wound in the same direction and the same magnetic polarity.
3. If there is a RWRP pickup this pickup needs to be replaced with a regular one, or you can modify it to become same polarity as the regular one
4. The pickups switching does not include any "in series" or "out of phase" combination

### **Preparing the guitar for CVNCS-R2 Installation:**

1. If you need to modify the single coil pickups - pull off all strings from tuners and modify the pickups accurately.
2. On the guitar back - unscrew and remove the plastic control cavity cover.
3. Take a picture or do a simple sketch to memorize the original wiring of your guitar electronics and the pickup wires connections for any future references.
4. If the pickup wires are braided type you will need to insulate them using shrink tubing or plastic jacket tubing so the pickup wires are not connected to each other or to the switch wire via the braided shield.
5. Take the Adjusting PCB and make sure that you will be able to fit it inside of the control cavity easily.

### **CVNCS-R2 installation steps:**

- A. Cut or unsolder the two pickup "Cold" wires (Ng and Bg) that were soldered to the Volume potentiometers housings.
- B. Fresh tin with soldering gun and fresh solder wire one of the short ground wires (G1) left on the Volume pots.
- C. Solder the cables coming out of the Adjusting PCB as follows:  
=Green wire to guitar ground - G1; White wire to Ng; Blue wire to Bg. Then insulate the created soldering joints.  
=Connect the red and yellow wires from the CVNCS-R2 coil to the red and yellow wires from the adjusting PCB and insulate the created joints.
- D. Use some clear tape pieces to place and hold the 4 plastic washers over the mounting screw holes of the control cavity. This is to avoid any bending of the CVNCS-R2 when final mounted. After finishing all soldering and insulations, shape the wire harness and place the CVNCS-R2 over the cavity and screw it in using only one or two screws. Keep the adjusting PCB outside of the control cavity until you finish the noise canceling adjustments.

### **Adjusting the CVNCS-R2 for best noise cancellation:**

1. Put ON some of the guitar strings (at least one), and turn the guitar volume and tone controls to their "MAX".
2. Connect the guitar to a guitar amplifier using a guitar cable.
3. Use a correct size screwdriver to adjust the blue trim pots located on the adjusting PCB.
4. Turn the two trim pots on the adjusting PCB to their "MAX" (100%). In this way you will be able to hear some basic hum noise.
5. Turn "ON" the guitar amplifier and set it up with a gain and loudness, so you can hear some noticeable hum noise. Play over the strings to check that all pickups operate normally and the hum noise has almost the same level at all 3 position of the pickup selector switch SW1.
6. Hold the guitar as you would play on it and get a position near the amplifier but not less than 3 feet (1 meter). Best noise canceling result will be achieved with the amplifier located behind your back and the guitar approximately parallel to the amplifier's front face.
7. Put the pickup selector switch SW1 at position "1" (Bridge pickup only). Turn down (CCW) VR1 trim pot to reduce the noise level. If the noise increases instead of decreasing, unplug the guitar from the amplifier remove the pickguard again and swap the wires connection as follows: yellow wire from the adjusting PCB to the red wire from the CVNCS-R2; red wire from the adjusting PCB to the yellow wire from the CVNCS-R2. Now turn down VR1 trim pot until get an optimum noise cancellation at position "1".
8. Put the pickup selector switch at position "3" (Neck pickup only). Turn slowly down (CCW) VR2 trim pot to reduce the noise until get an optimal noise cancellation at position "3".
9. You can now go back and forth through all 3 positions (Bridge; Bridge + Neck; Neck) of the SW1 and fine adjust the locations of the VR1 and VR2 until you get the best noise cancellation. After you are satisfied with the noise reduction result, wrap out the adjusting PCB with a small plastic bag or piece of foam, and insert it under the cover.
10. Set up the guitar, plug it in and double check for its normal operation.

**Basic Wiring diagram. Use this wiring ONLY if the two SC pickups are same polarity (hum noise at ALL 3 positions)!**  
 Find your color wiring diagrams on the website - [www.ilitchelectronics.com/wirings/](http://www.ilitchelectronics.com/wirings/)

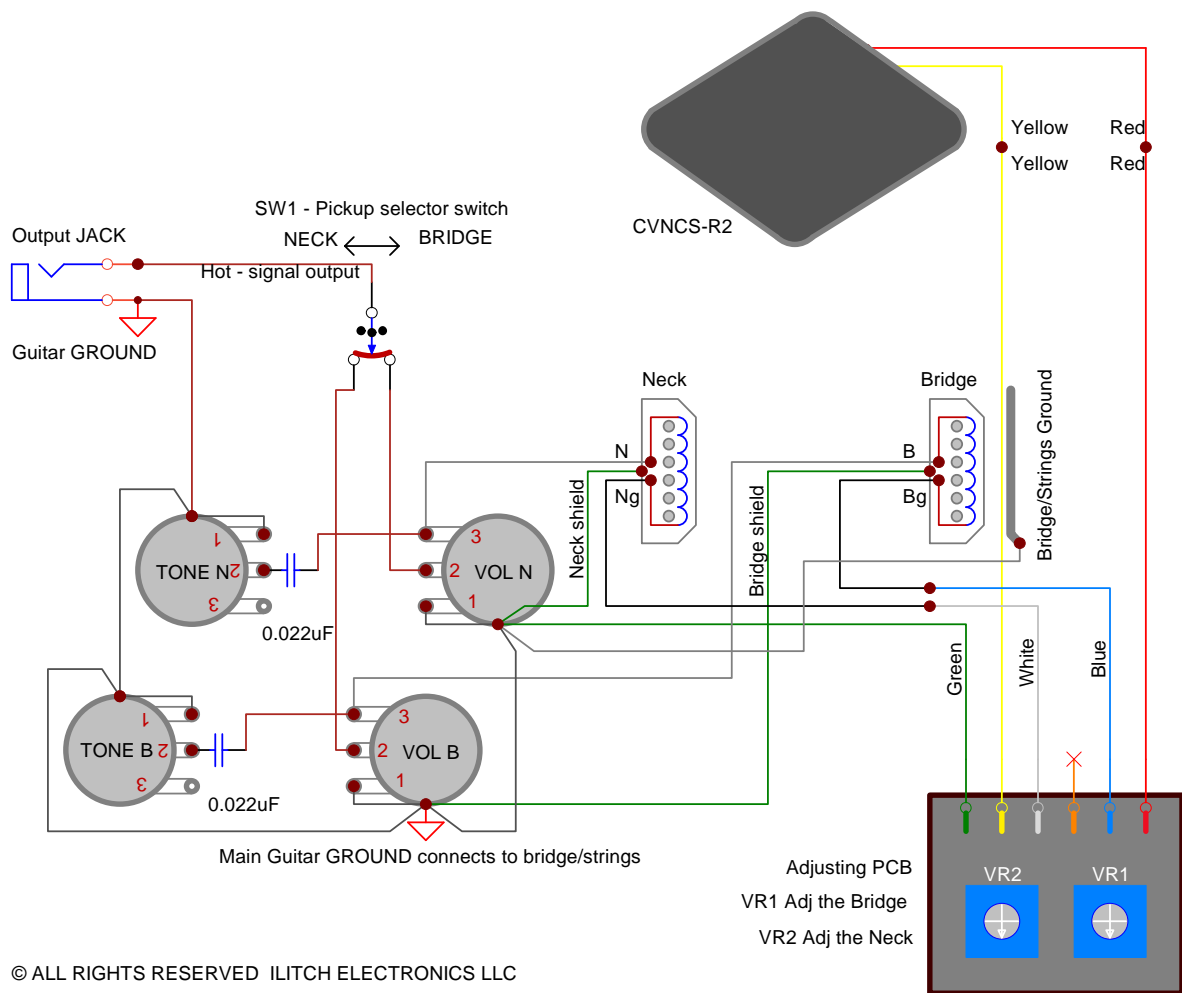

Terms of Limited Warranty. RETURN & EXCHANGE POLICY:

We offer to the original purchaser (For DIRECT SALES from ILITCH ELECTRONICS ONLY) the following terms of Limited Warranty and RETURN & EXCHANGE POLICY:

1. One year of warranty for all moving parts (i.e. trim potentiometers) of the product.
2. Two years warranty for all non-moving parts (i. e. - capacitors, resistors etc.) of the product. Ilitch Electronics reserves the right, based on visual observing and electrical measuring, to determine what has caused a defect. Damages caused by accident, abuse, alteration, or misuse are not covered by this warranty. Product appearance and normal "wear and tear" (worn paint, scratches, etc.) are not covered by this warranty.
3. We offer a four weeks money back policy for customers not satisfied with the purchase. You have to contact us first to get a return authorization number.

A refund will exclude all shipping and handling costs and an additional 15% restocking fee will be applied. The product needs to be in its original condition and packaging that you have received it from us.

Customer's Name:..... Date of purchase :.....

All rights reserved without notification.  
 ILITCH ELECTRONICS LLC  
 Camarillo, CA, 93010  
 Phone: 805 284 2775;  
 email: [ilitch@ilitchelectronics.com](mailto:ilitch@ilitchelectronics.com)  
 Web: [www.ilitchelectronics.com](http://www.ilitchelectronics.com)