

Pick Guard Noise Canceling System - Tele (PGNCS-T2)

User's manual and installation instructions

Tele style guitars that have vinyl plastic pickguard and two single coil guitar pickups can be retrofitted with the PGNCS-T2. The PGNCS-T2 replaces the existing Tele pickguard originally mounted on the front of the guitar body. The PGNCS-T2 effectively eliminates the hum while the single coil pickup tone remains unaltered. It is an easy to install passive system.

The best way to install the PGNCS-T2 is to use professional service of a guitar builder or guitar repair shop but it can be also installed by anyone that is familiar with guitar electronics, guitar assembling and wire soldering. Drilling holes, scratching isolation or ANY heavy bending of the PGNCS-T2 could badly damage the unit and cause you to lose all terms of the warranty.

Tools and materials needed for installation:

Soldering gun, screw driver, wire cutters, soldering wire, shrink tubing, flexible hook up wires.

Optional: digital multimeter, piece of foam, small plastic bag, electrical/masking tape.

Preparing guitar with pickguard for PGNCS-T2 installation:

1. Pull OFF all strings from the tuners to get a full access to the pickups and pickguard.
2. On the guitar front - unscrew and remove the entire pickguard.
3. Open the control cavity
4. Take pictures or do a simple sketch to memorize the original wiring of the guitar electronics and the pickup wires connections for any future references.
5. If the pickup wires are braided type you will need to isolate them using shrink tubing or plastic jacket tubing so the pickup wires are not connected to each other or to the switch wire via the braided shield.
6. Refer to our Blog page (<http://www.ilitchelectronics.com/blog/>) for the Bridge and Neck pickup output wires modification
7. Find the right place for the Adjusting PCB inside of the control cavity.

PGNCS-T2 installation steps: (Refer to our website for more detailed instructions and photos)

- A. Cut or unsolder the two pickup ground wires (Ng and Bg) soldered to the volume potentiometer housing.
- B. Tin with soldering gun and fresh solder wire one of the short ground wires left on the Volume potentiometer.
- C. Solder the wires coming out of the Adjusting PCB as follows:
=Green wire to GROUND; White wire to Ng; Blue wire to Bg. Then isolate the created soldering joints.
=Connect yellow wire from the adjusting PCB to yellow wire from the PGNCS-T2; red wire from the adjusting PCB to red wire from the PGNCS-T2 and isolate the created wire joints.
- D. Carefully position the PGNCS-T and align the mounting holes to match with the original ones. After finishing all soldering and isolations, shape the wire harness, place back the PGNCS-T and screw it in using some of the mounting screws. Keep the adjusting PCB outside of the control cavity until you finish the noise canceling adjustments.

Adjusting the PGNCS-T2 for best noise cancellation:

1. Put ON some of the guitar strings (at least one), and turn the guitar volume and tone controls to their "MAX".
2. Connect the guitar to a guitar amplifier using a guitar cable.
3. Use a correct size screwdriver to adjust the blue trim pots located on the adjusting PCB.
4. Turn the two trim pots on the adjusting PCB to their "MAX" (100%). In this way you will be able to hear some basic hum noise.
5. Turn "ON" the guitar amplifier and set it up with a gain and loudness, so you can hear some noticeable hum noise. Play over the strings to check that all pickups operate normally and the hum noise has almost the same level at all 3 position of the pickup selector switch SW1.
6. Hold the guitar as you would play on it and get a position near the amplifier but not less than 3 feet (1 meter). Best noise canceling result will be achieved with the amplifier located behind your back and the guitar approximately parallel to the amplifier's front face.
7. Put the pickup selector switch SW1 at position "1" (Bridge pickup only). Turn down (CCW) VR1 trim pot to reduce the noise level. If the noise increases instead of decreasing, unplug the guitar from the amplifier remove the pickguard again and swap the wires connection as follows: yellow wire from the adjusting PCB to the red wire from the PGNCS-T2; red wire from the adjusting PCB to the yellow wire from the PGNCS-T2. Now turn down VR1 trim pot until get an optimum noise cancellation at position "1".
8. Put the pickup selector switch at position "3" (Neck pickup only). Turn slowly down (CCW) VR2 trim pot to reduce the noise until get an optimal noise cancellation at position "3".
9. You can now go back and forth through all 3 positions (Bridge; B+N; Neck) of the SW1 and fine adjust the locations of the VR1 and VR2 until you get the best noise cancellation. After you are satisfied with the noise reduction result, wrap out the adjusting PCB with a small plastic bag or piece of foam, and insert it under the pickguard.
10. Align the guitar pickguard and screw it in using all mounting screws. Double check for normal operation of the guitar.

Basic Wiring diagram. Use this wiring ONLY if the two SC pickups are same polarity (hum noise at ALL 3 positions)!
 Find your color wiring diagrams on the website - www.ilitchelectronics.com/wirings/

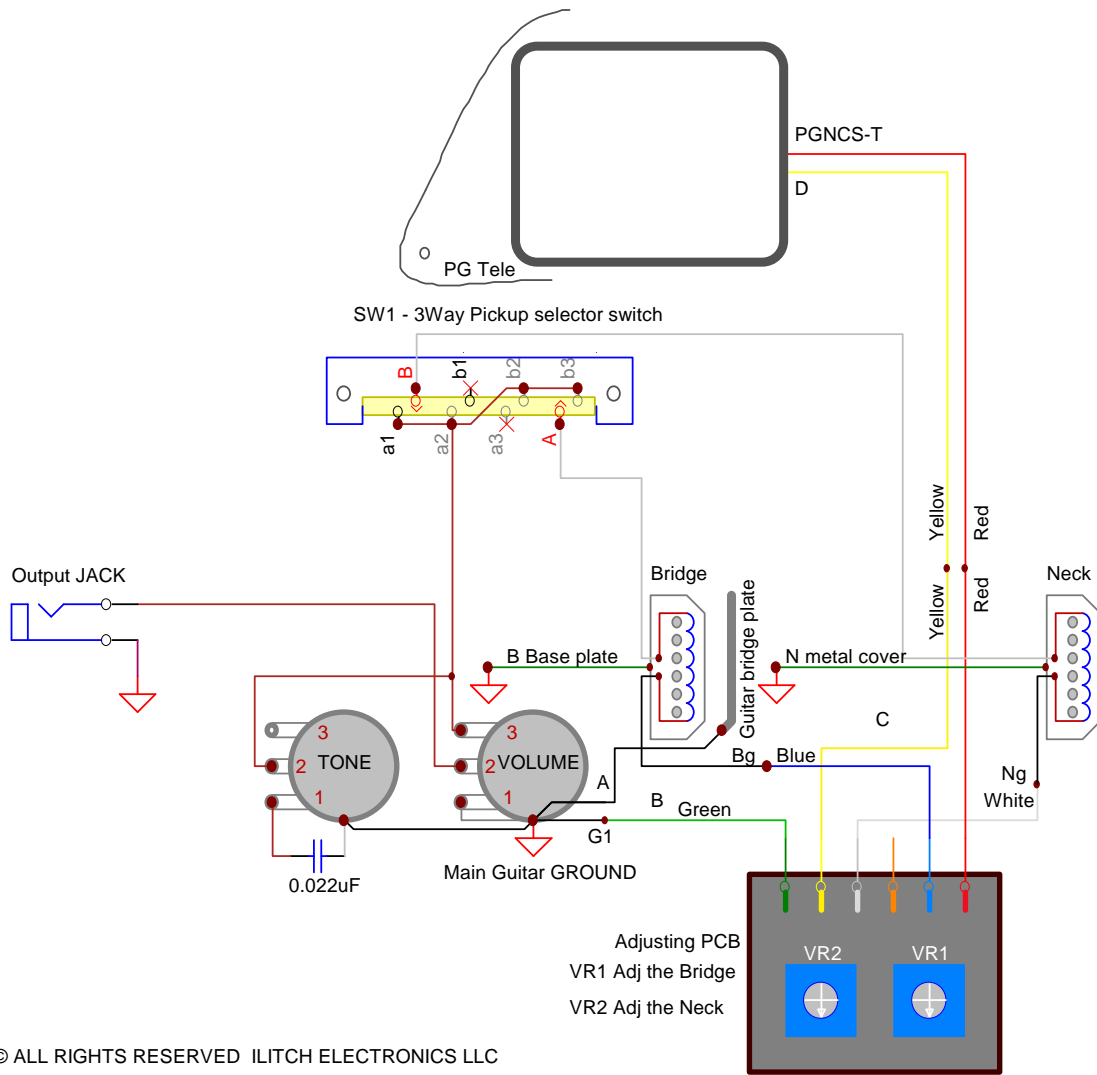

Terms of Limited Warranty. RETURN & EXCHANGE POLICY:

We offer to the original purchaser (For DIRECT SALES from ILITCH ELECTRONICS ONLY) the following terms of Limited Warranty and RETURN & EXCHANGE POLICY:

1. One year of warranty for all moving parts (i.e. trim potentiometers) of the product.
2. Two years warranty for all non-moving parts (i. e. - capacitors, resistors etc.) of the product. Ilitch Electronics reserves the right, based on visual observing and electrical measuring, to determine what has caused a defect. Damages caused by accident, abuse, alteration, or misuse are not covered by this warranty. Product appearance and normal "wear and tear" (worn paint, scratches, etc.) are not covered by this warranty.
3. We offer a four weeks money back policy for customers not satisfied with the purchase. You have to contact us first to get a return authorization number (RAN). A refund will exclude all shipping and handling costs PayPal fees and an additional 15% restocking fee will be applied. The product needs to be in its original condition and packaging that you have received it from us.

Customer's Name:..... Date of purchase :.....

All rights reserved without notification.
 ILITCH ELECTRONICS LLC
 Camarillo, CA, 93010
 Phone: 805 284 2775;
 email: ilitch@ilitchelectronics.com
 Web: www.ilitchelectronics.com